

HUBER+SUHNER[®]

SENCITY[®] ROAD ANTENNA

FOR WIRELESS COMMUNICATION



Mounting Instruction



Keep away from catenary and high voltage lines.
Be careful when working at height!
Always secure ladders!
Always tighten screws!



Caution! ESD (electrostatic discharge) sensitive device.
Always ground yourself while handling the GPS connector.
For more information, see the Security Instruction for this product on the HUBER+SUHNER website.

Dimensions in millimeter [mm]



Avoid bringing the cover of the antenna into contact with acetone, gasoline or oil.

Mounting surface

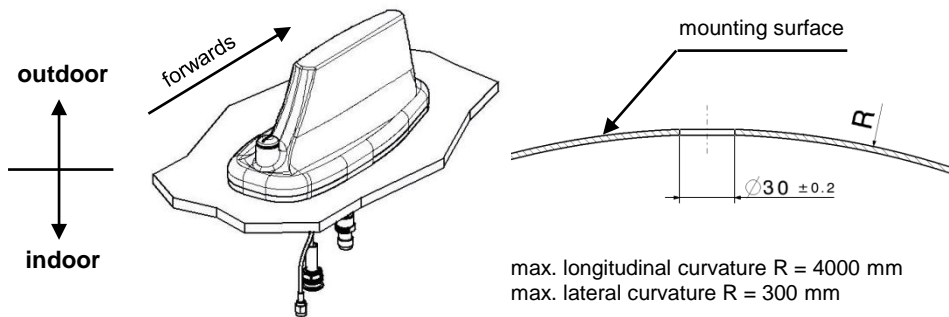

The area of the roof where the antenna will be mounted has to be stable and preferably flat.

Roof thickness: 0.9 mm to 10 mm

NOTE: If you wish to attach a monopole stick antenna and the roof is plastic, remember to allow sufficient space inside vehicle for the metal ground plane (see below).

Drilling of hole and preparation of roof

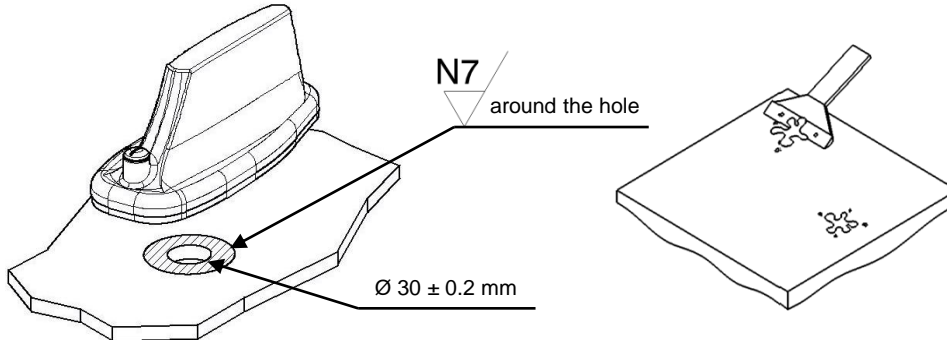

Drill the mounting hole.

Clear the area around the hole from any corrosion, roughness, grease, oil, swarf or dust.

Creating a larger ground plane (if using a monopole stick antenna on a plastic roof)

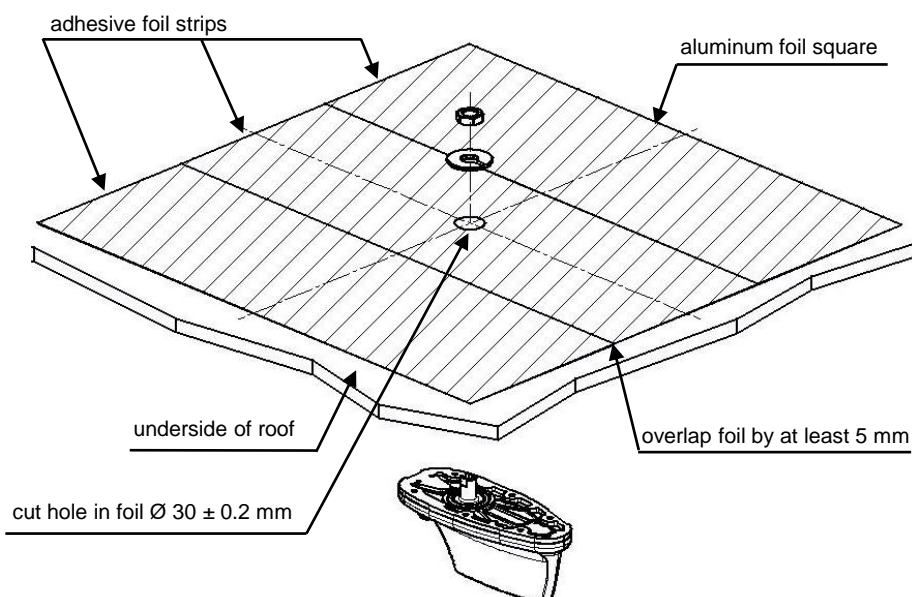

Adhesive aluminium foil can be used to create a square ground plane on the inner surface of a plastic roof.

Adhesive foil strips are available from HUBER+SUHNER as an accessory. See the datasheet of the relevant monopole stick antenna for details.

Ensure the inner roof surface is clean and dry.

Once the foil has been applied, cut a hole as shown, matching the hole in the roof.

Cut the foil so that it is square and the hole is in the centre of the square.

Installation of the antenna

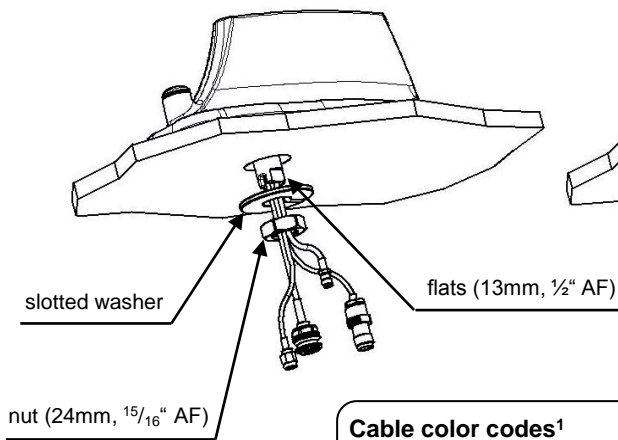

Cable color codes¹

White	-	Cellular bands
Blue	-	WLAN / WIFI
Black	-	GPS ²
Red	-	Monopole stick antenna
Yellow	-	TETRA (internal)
Green	-	DVB-T

Connector torques

SMA	-	1.0 Nm
TNC	-	0.6 Nm

¹ Not all cables are present on some models.

² Inner conductor: 3..5 V. Outer conductor: GND.

Loosen the nut from the shaft.

Remove the slotted washer.

Pass the cables through the hole.

Replace the slotted washer with stepped face towards hole.

Fasten the nut. Torque: 15 ± 2 Nm.

Use the flats on the antenna shaft to prevent the antenna from rotating while fastening.



Connect the cables. **Take ESD precautions!** Use cable holders to avoid tension on the connectors.

The cables can be recessed into the slot in the shaft to minimize installation depth.

Cable minimum bending radius: 5mm (static).

Unused connectors must be terminated.

Attachment of a monopole stick antenna (if required)

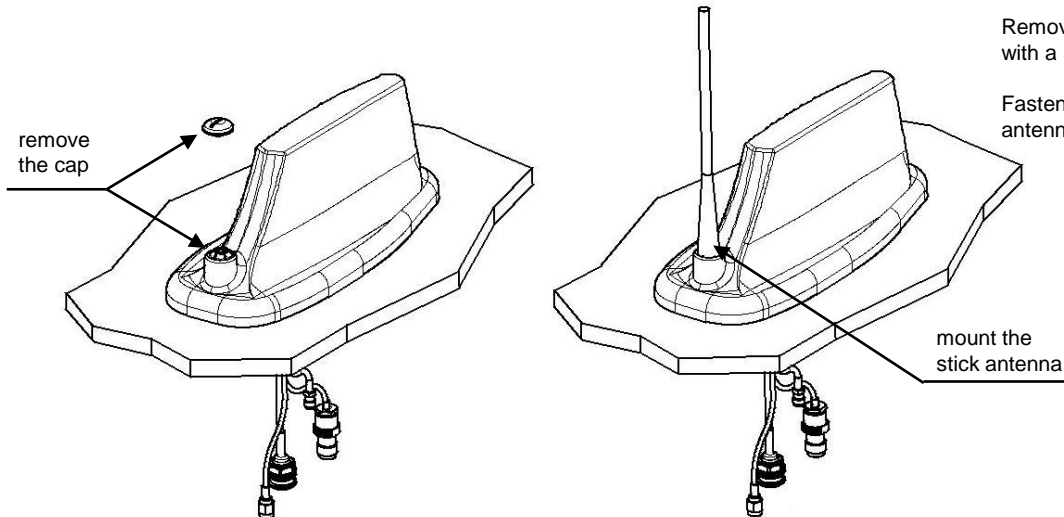

Remove the cap with a screwdriver.

Fasten the monopole stick antenna.

General remarks

In the final position of the antenna, the draining hole and the connectors need to be protected against environmental impacts (indoor environment). Otherwise a cable conduit has to be used.

This product can be returned to HUBER+SUHNER for recycling at the end of its useful life. Please contact your local agent.

HUBER+SUHNER is certified according to ISO 9001 and ISO 14001

WAIVER!

It is exclusively in written agreements that we provide our customers with warrants and representations as to the technical contained specifications and/or the fitness for any particular purpose. The facts and figures herein are carefully compiled to the best of our knowledge, but they are intended for general informational purposes only.

HUBER+SUHNER – Excellence in Connectivity Solutions



HUBER+SUHNER AG

RF Technology

9100 Herisau, Switzerland

Phone +41 (0)71 353 41 11

Fax +41 (0)71 353 47 51

www.hubersuhner.com

Doc. No. 0000361395

Art. No. 84124409

Revision E

Page 2 of 2